

SIMULATION OF CANAL NETWORK FLOW IN THE SOUTH FLORIDA REGIONAL SIMULATION MODEL

Randy Van Zee, A. M. Wasantha Lal, Mark Belnap
*Supervising Professional, Lead Engineer, Senior Engineer, Hydrologic Systems
Modeling Department, South Florida Water Management District.*

ABSTRACT

The weighted implicit finite volume approach for 2-D flow is extended to model canal flow in the South Florida Regional Simulation Model (SFRSM). St Venant equations with the diffusion approximation are used as governing equations. The water body and water mover base classes are used to represent canal segments and junctions in the 1-D model in an object oriented framework. Ground water and surface water flow is integrated with canal flow through flow functions attached to segment walls. The model uses an external sparse solver to solve overland, ground and canal flows simultaneously. The method is stable because of the implicit formulation. This paper describes the theory and provides a sample application.

INTRODUCTION

Regional simulation models play a key role in the planning, management and operation of the complex hydrologic system in south Florida. The South Florida Water Management Model (SFWMM) was developed during the late 1970s and early 1980s and has served as the primary regional simulation model in south Florida for nearly two decades. New initiatives such as the Everglades Restoration, and Water Supply Planning have placed new demands for information from regional simulation models. The South Florida Regional Simulation Model (SFRSM) will be the next generation SFWMM that will use recent advances in computer technology, in particular, Geographical Information Systems, Databases, and Object Oriented methodologies. The SFRSM will also make use of the more accurate and efficient numerical algorithms to simulate hydrology and water management in south Florida using a variable mesh structure.

The Hydrologic Simulation Engine (HSE) was developed to provide more flexible and detailed hydrologic analysis within the SFRSM. A weighted implicit finite volume method is used in the HSE to solve the diffusion type overland flow and ground water flow equations (Lal, et al., 1998). The physical domain is ideally suited to be implemented as objects. The two fundamental objects are water bodies and water movers.

Water bodies are places to store water. Water movers provide a means of water transfer. Because the transfer of water between water bodies is through water movers, water mover objects have the responsibility of computing how much flow occurs. To do this they use a variety of user-selectable methods that model overland flow and ground water flow. A linearized coefficient is produced by each of these methods and inserted in a stiffness matrix “K”. The final value stored in “K” is a combination of all the flow methods and indicates the total amount of water transferred between water bodies. The governing equation is written in terms of K and is used to obtain a weighted implicit formulation that can be solved as a system of linear equations for water level. Canals in the one-dimensional network model can be discretized in the same way as the two-dimensional domain is discretized. Canal segments are water bodies that store water. Junctions between canal segments and walls between a canal segment and 2-D cells act as water movers, transferring water from canal segment to adjacent segments and cells, respectively.

GOVERNING EQUATIONS FOR CANAL FLOW

One dimensional flow is approximated using diffusion flow equations, assuming that the inertia terms can be neglected. The current 1-D model is capable of simulating flow through structures and junctions, and considers the effects of different head and discharge boundary conditions. In the coupled system consisting of 2-D overland/ground water flow and 1-D canal flow, the canal system is laid over the 2-D system, and the interaction or leakage terms are computed using water levels and physical characteristics of both systems. Figure 1 shows a definition sketch showing the placement of the canal segments in the cell.

Gradually varied 1-D unsteady flow is explained using the depth averaged flow equations commonly referred to as Saint Venant equations. The first of the two equations is the continuity equation.

$$\frac{\partial A}{\partial t} + \frac{\partial Q}{\partial x} + q_l = 0 \quad (1)$$

in which, x is the distance measured along the canal; A = flow cross sectional area; Q = discharge through A ; q_l = overland flow entering into the canal per unit length. Rainfall and evapotranspiration are assumed to be taking place only in the 2-D overland flow area. The second of the two equations is the momentum equations.

$$\frac{\partial Q}{\partial t} + \frac{\partial}{\partial x} \left(\beta \frac{Q^2}{A} \right) + gA \left(\frac{\partial H}{\partial x} + S_f \right) = 0 \quad (2)$$

in which, S_f = friction slope in x direction; H = water level; β = momentum correction coefficient. After neglecting the first three terms contributing to inertia effects, the momentum equation in reduces to $\frac{\partial H}{\partial x} = -S_f$ in which, $H = h + z =$ water level above a datum; $z =$ bottom elevation above datum. Friction slope S_f is related to the velocity using a general form of the Manning’s equation is written as $V = \frac{1}{n} R^\lambda S_f^\lambda$ in

which $R = A/P$ = hydraulic radius; P = wetted canal perimeter; n = Manning's coefficient when $\gamma = 2/3$ and $\lambda = 1/2$; and S_f = friction slope. Akan and Yen (1981), Hromadka et al. (1987), and others showed that flow velocity component u can be expressed in the following form using Manning's equations.

$$Q = -K \frac{\partial H}{\partial x} \quad (3)$$

in which, K can be expressed for the Manning's equation as

$$K = \frac{1}{n} AR^\gamma S_f^{\lambda-1} \quad \text{for } \lambda \geq 1, \quad |S_f| > S_{tol} \quad (4)$$

$$K = \frac{1}{n} \frac{AR^\gamma}{S_{tol}^{1-\lambda}} \quad \text{for } \lambda < 1, \quad |S_f| \leq S_{tol} \quad (5)$$

S_{tol} = a cutoff level of friction slope below which the flow is assumed to be negligible. S_{tol} is also used to bound K within finite limits. The continuity equation Eq. 1 can now be expressed using Eq. 3 as

$$\frac{\partial A}{\partial t} = \frac{\partial}{\partial x} \left(K \frac{\partial H}{\partial x} \right) + q_l \quad (6)$$

This equation can be solved as a non-linear diffusion equation.

GOVERNING EQUATIONS FOR CANAL INTERACTIONS

The system in south Florida is unique because of the presence of strong interaction of overland and ground water flow in canals and ponded areas. Leakage between the canal and the ground water aquifer can be expressed as

$$q_l = \frac{k_m P \Delta H}{B \delta} \quad (7)$$

in which, k_m = transmissivity coefficient for sediment layer; P = wetted perimeter; B = width of canal; ΔH = head difference between the cell and the canal segment; δ = thickness of sediment layer;

Overland flow gets in and out of canals mainly during storm events. Simple kinematic flow assumptions are used to compute flow rates based on the Manning's equation. Flow is assumed to take place under two different conditions which depend on the water levels of the canal and the ground. The equations for flow rate are developed for conditions under which the flow rate can be downstream dependent and independent. Overland flow rate into a canal can be computed using an equation based on the Manning's equation. When the downstream water level is well below the bank level, the downstream independent flow occur (Figure 2). Under downstream independent flow conditions,

$$Q_o = \frac{1}{n_b} \sqrt{S_0} (H - z - d_d)^{\frac{5}{3}} \quad (8)$$

in which, Q_o = flow rate per unit length of canal; n_b = Manning's roughness of overland flow; S_0 = bed slope of the overland flow area; and d_d = detention depth.

Under downstream dependent flow conditions,

$$Q_o = \frac{1}{n_b} (H - z - d_d)^{\frac{5}{3}} \sqrt{\frac{4(H - H_c)}{\Delta x}} \quad (9)$$

$\Delta x = \sqrt{\Delta A}$ was assumed for triangular cells.

NUMERICAL METHOD

Solution of the St. Venant equations or its diffusion flow form requires discretization of the canal system. In order to obtain a finite volume type formulation, the governing equation is expressed in the following integral form over the canal system.

$$\frac{\partial}{\partial t} \int_{cv} A dv - \int_{cv} \frac{\partial Q}{\partial x} dx + \int_{cv} q_{ae} dv = 0 \quad (10)$$

For a single canal segment i of plan area $B_i \Delta x_i$, the continuity equation can be expressed as

$$B \Delta x \frac{\partial H}{\partial t} = [\sum Q_{in} - \sum Q_{out} + q_{ae}] = 0 \quad (11)$$

in which, Q_{in} and Q_{out} are flows in and out of the canal segment from neighboring canal segments.

When using an object oriented formulation, canal segments are considered as water body objects having uniform cross sectional properties. These segments are connected to each other at junctions located at each end. Junctions act as water movers, controlling the flow between segments. The friction relationships between the canal segments form the basis of all the flow computations in the network. In the case of structures, the friction relationship is derived from the structure equations. In the case of open channel flow, the Manning's equation is used instead. If the water levels of two canal segments i and j are H_i and H_j , the open channel flow between the segments can be expressed as

$$Q = K_{i,j} (H_i - H_j) \quad (12)$$

in which

$$K_{ij} = \frac{\bar{A}}{(l_i + l_j) \sqrt{S_n} \bar{n}_b} \left(\frac{\bar{A}}{\bar{P}} \right)^{\frac{5}{3}} \quad (13)$$

and

$$\bar{A} = A_i + A_j \quad (14)$$

$$\bar{P} = P_i + P_j \quad (15)$$

$$\bar{n}_b = n_{bi} + n_{bj} \quad (16)$$

$$S_n = \frac{|H_i - H_j|}{l_i + l_j} \quad (17)$$

$$l_i = 0.5\Delta x_i \quad (18)$$

A_i = cross sectional area of canal segment i ; P_i = wetted perimeter of the canal segment i ; n_{bi} = Manning's roughness of canal segment i ; and Δx_i = length of canal segment i .

Using the above linearization, the continuity equation for a canal segment i can be expressed as

$$B_i \Delta x_i \frac{\partial H_i}{\partial t} = \left[\sum_{j=1}^{nd} K_{ij} H_j + q_{ae,i} \right] = 0 \quad (19)$$

in which, $j = 1, 2, \dots, nd$ are the flow pairs sending water to canal segment i . Since the governing equation is cast in the form

$$\mathbf{A} \frac{d\mathbf{H}}{dt} = \mathbf{M} \mathbf{H} + \mathbf{S} \quad (20)$$

and the diagonal matrix \mathbf{A} is defined as

$$\Delta A_{ii} = B_i \Delta X_i \quad (21)$$

Equation 20 can be numerically solved using the same method used with the 2-D diffusion flow problem.

The interactions between the canals and cells introduce terms to the system of differential equations. The system of equations is written in a form consistent with Equation 20. In order to assemble the corresponding terms in the \mathbf{M} matrix, following water balance equations are written describing the leakage between cells and the canals. Flow rate into a canal segment is given by

$$\Delta A_{cj} \frac{dH_{cj}}{dt} = \sum_{i=1}^{n_j} B_{ij} G_{ij} (H_i - H_{cj}) \quad (22)$$

in which, ΔA_{cj} = open water area of the canal segment j computed as $w_i \Delta x_j$; H_{cj} = water level in the canal segment j ; B_{ij} = overlapping length between the canal link j and the cell i ; G_{ij} = canal reach transmissivity between link j and cell i ; n_j = number of cells interacting with canal link j .

The flow rate into a cell given by the following equation describes the water balance with respect to cells.

$$\Delta A_i \frac{dH_i}{dt} = \sum_{j=1}^{n_i} B_{ij} G_{ij} (H_{cj} - H_i) \quad (23)$$

Figure 3 shows the placement of these new elements in the composite \mathbf{M} matrix. Interaction terms add elements to the i, i and j, j places as well as the i, j and j, i places. For the j th link, the row and the column numbers are counted as $ne + j$ and $ne + j$ in which ne is the number of triangular cell elements.

APPLICATION

The test application consists of a 1 mile channel splitting into a 2 mile channel and a 3 mile channel. Overland and ground water interactions were not included. The properties of the three straight channels are shown in Figure 4. Manning's roughness was assumed to be 0.02 for all channels. The flow hydrograph at the inflow begins as steady flow of $589.7 \text{ m}^3/\text{s}$, and increases linearly from $589.7 \text{ m}^3/\text{s}$ to $1415.8 \text{ m}^3/\text{s}$ in 20 minutes and decreases linearly to $589.7 \text{ m}^3/\text{s}$ in 40 more minutes. The downstream ends have head boundary conditions, with water levels specified as 2.017 m and 1.213 m at segments 2 and 3.

Figure 5 shows a comparison of the HSE with UNET (HEC, 1996) results. Simulated water levels from the HSE and UNET models nearly coincide at the upstream end of reach 1. At the downstream end of reach 3, the simulated discharge for UNET generally coincides with HSE except at the peak where UNET discharge is $2 \text{ m}^3/\text{s}$ greater than HSE. This deviation is most likely due to differences in formulation (diffusion approximation versus the Priessmann scheme for UNET). These differences, plus the influence of canal and cell interactions will be addressed in future studies.

SUMMARY

The weighted implicit finite volume approach developed for 2-D flow can be extended to canal flow. Moreover the same object oriented framework developed for 2-D flow can be used to model canal flow, as well as canal and cell interactions. Comparisons between UNET and HSE show the two models generally give comparable results.

REFERENCES

1. Akan, A. O., and Yen, B. C. (1981). "Diffusion-wave flood routing in channel networks", *J. Hydr. Div.*, ASCE, 107(6), 719-731.
2. Hromadka II, T. V., McCuen, R. H., and Yen, C. C. (1987). "Comparison of overland flow hydrograph models", *J. of Hydr. Res.*, ASCE, 113(11), 1422-1440.
3. Lal, Wasantha, A. M. (1998) "A weighted finite volume model for overland flow", *J. Hydraul. Eng.*, 124(9).

4. HEC, 1996, "One-dimensional unsteady flow through a full network of open channels", *U.S. Army Corps of Engineers*, Davis, CA.

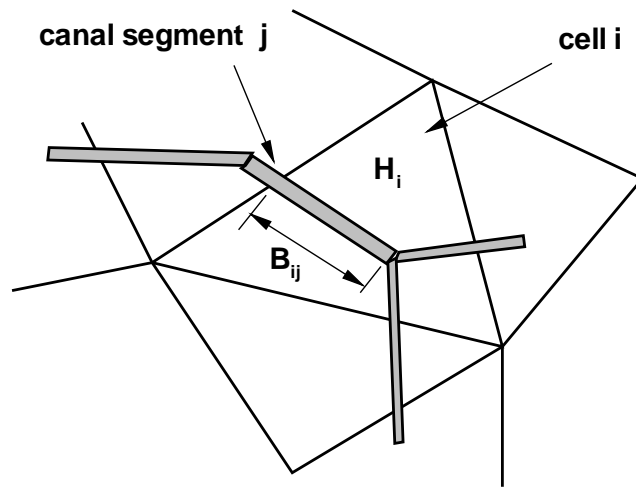

Figure 1: Definition sketch showing the placement of canal links in triangular cells

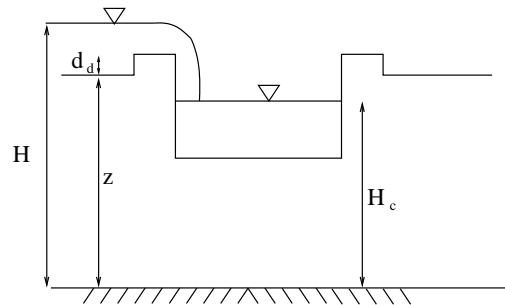

Figure 2: Definition sketch showing canal cross section.

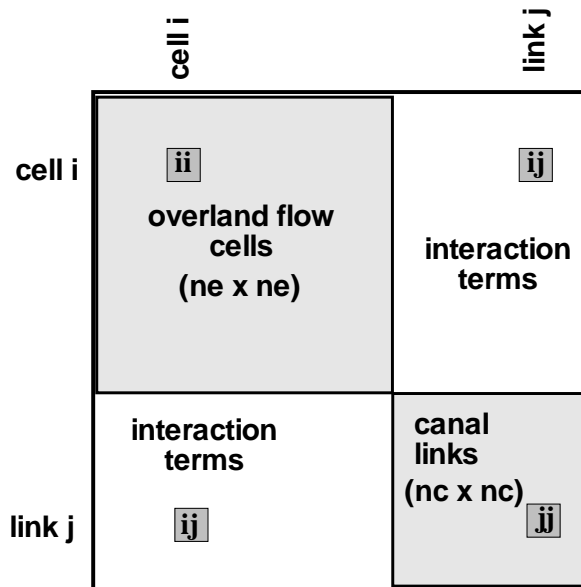

Figure 3: Configuration of the sparse matrix showing the interaction terms.

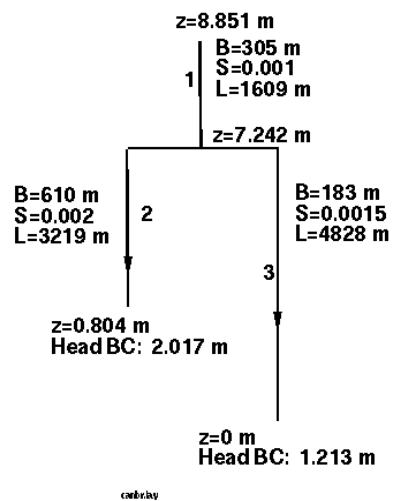

Figure 4: Canal configuration used for test application.

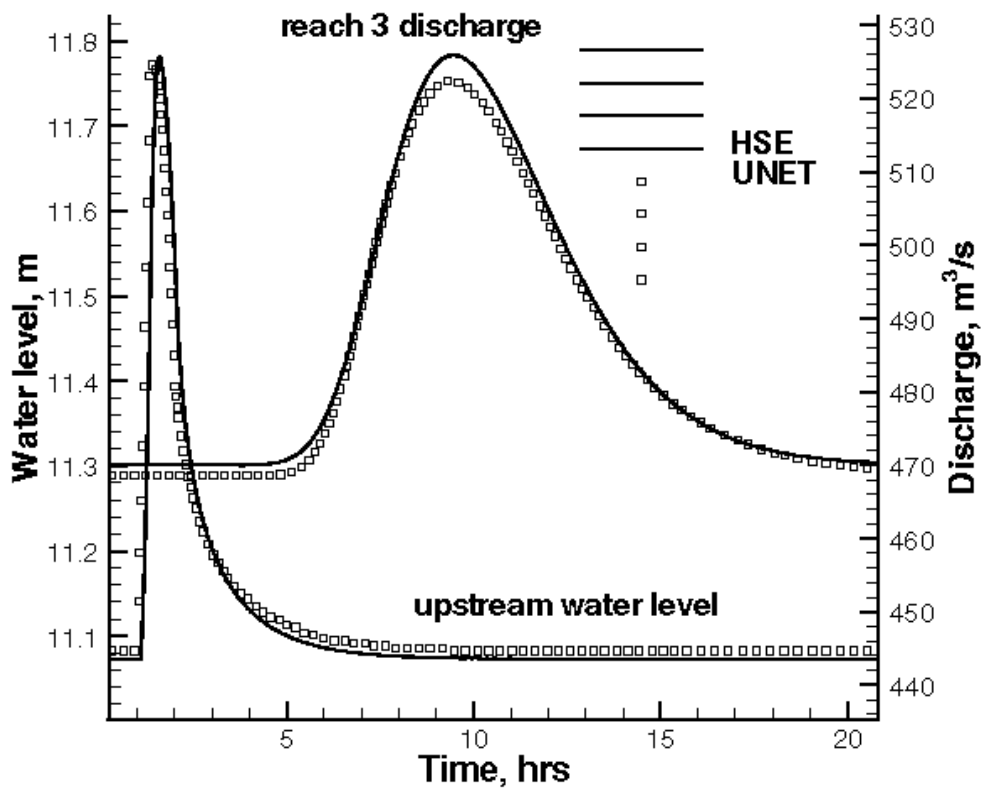

Figure 5: Comparison of HSE and UNET model results.